



# **A Level Design & Technology : OCR**

H406 Product Design



## Key Features

Here at St Francis of Assisi CTC we offer 'Product Design'.

- Students have a breadth of teaching styles
- Staff expertise can be shared across all Post 16 students
- Students can access all resources within DT and not just those typically associated with the chosen area.

The content of all the OCR Design Technology qualifications have been set out in the following sections:

- Identifying requirements
- Learning from existing products and practice
- Implications of wider issues
- Design thinking and communications
- Material considerations
- Technical understanding
- Manufacturing processes and techniques
- Viability of design solutions
- Health and safety



## Product Design:

The subject content of this title is focused towards consumer products and applications; their analysis in respect of materials, components, and marketability to understand their selection and uses in industrial and commercial practices of product development.

# What will your lessons look like?

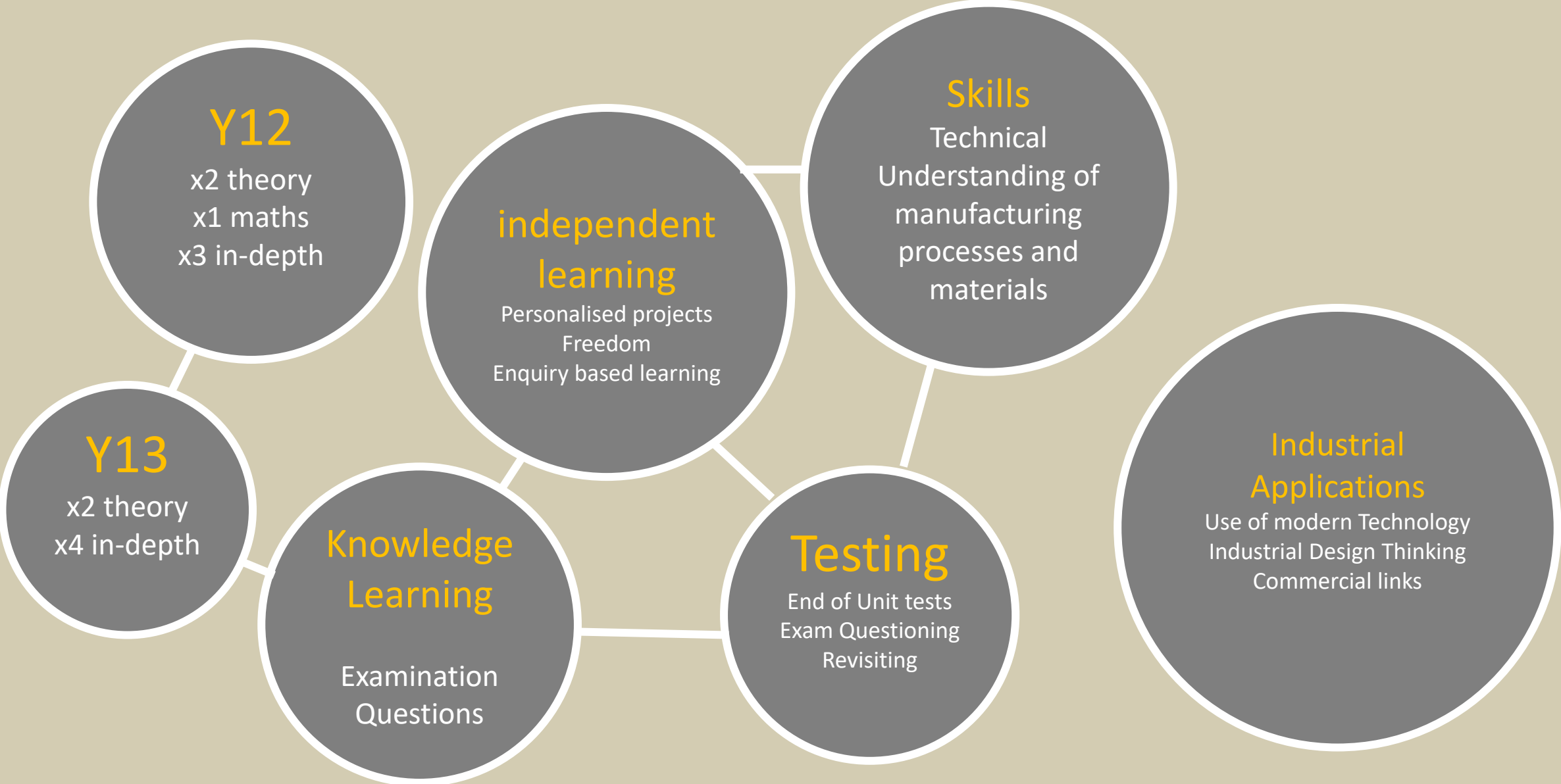

# Design Concept



Original Influence  
1980 Durabeam torch

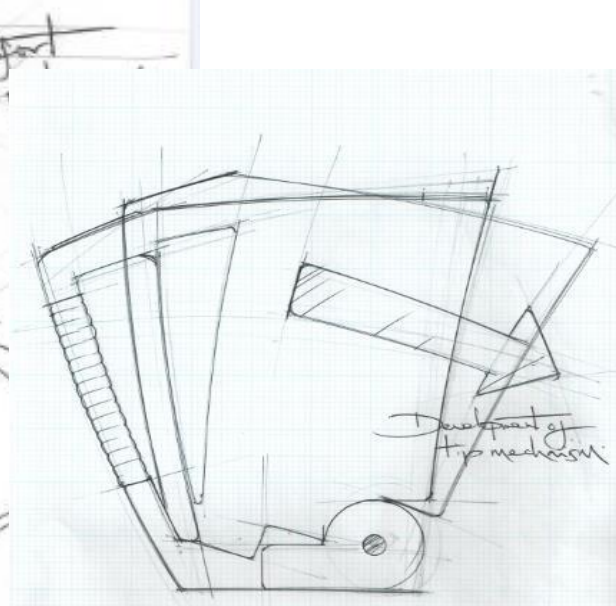
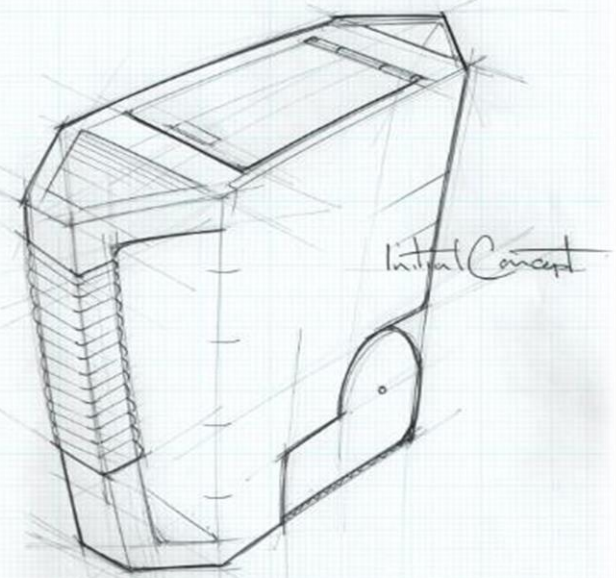
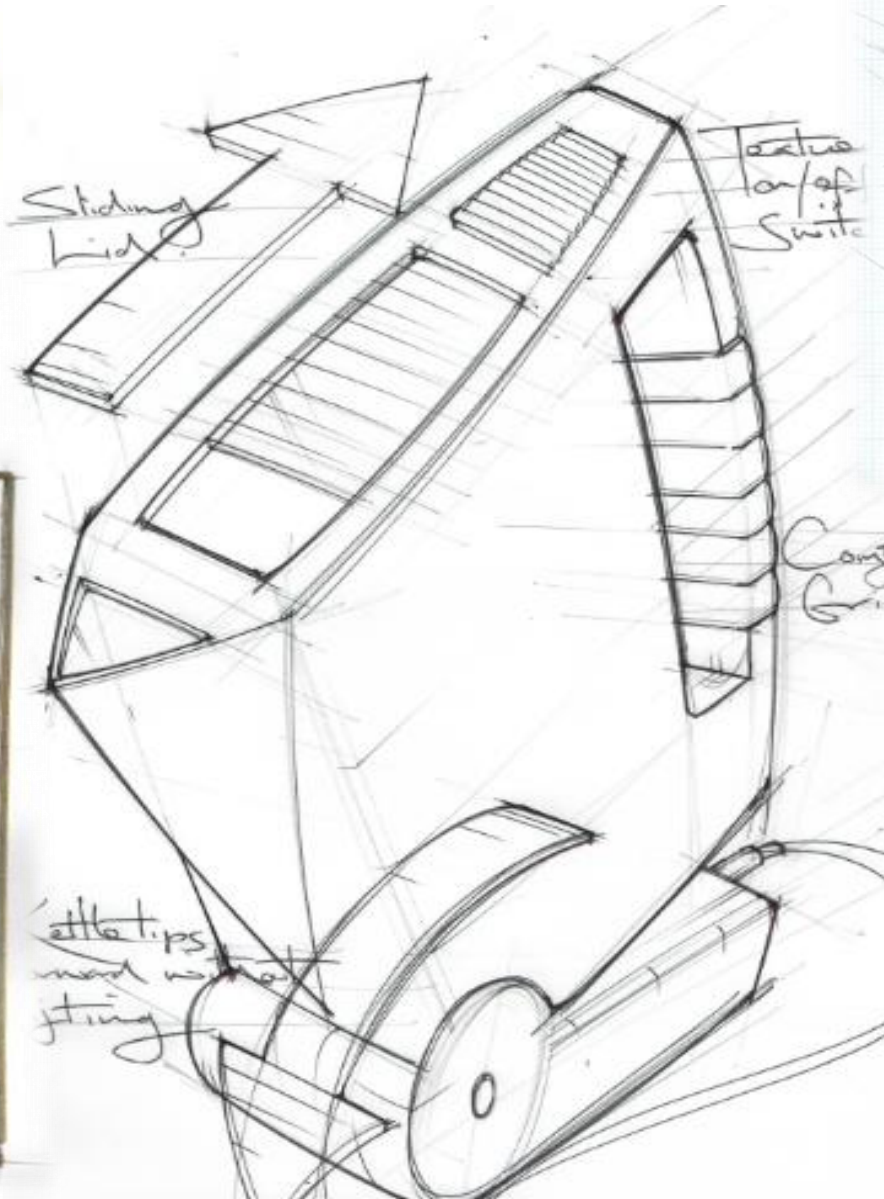
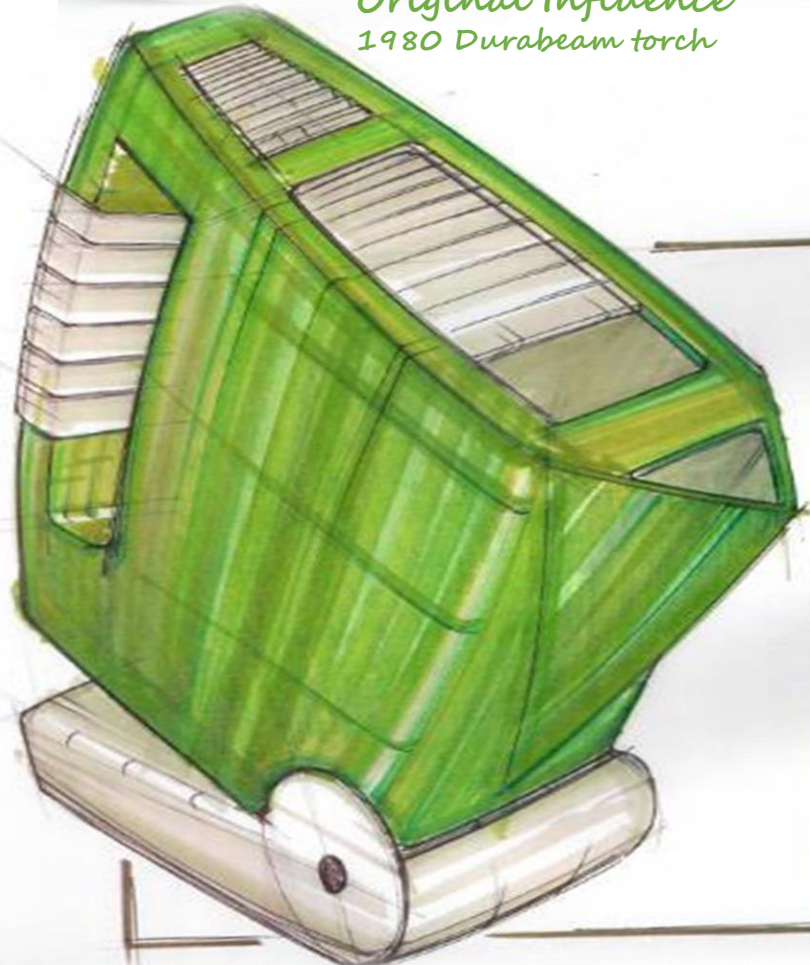

# Modelling

The model required two pieces of Styrofoam to be joined using PVA glue.



The curved shape was initially drawn onto the end ready for cutting on the bandsaw.



The waste material was taped back on to retain the square block making it easier to hold when cutting the circle at the bottom.

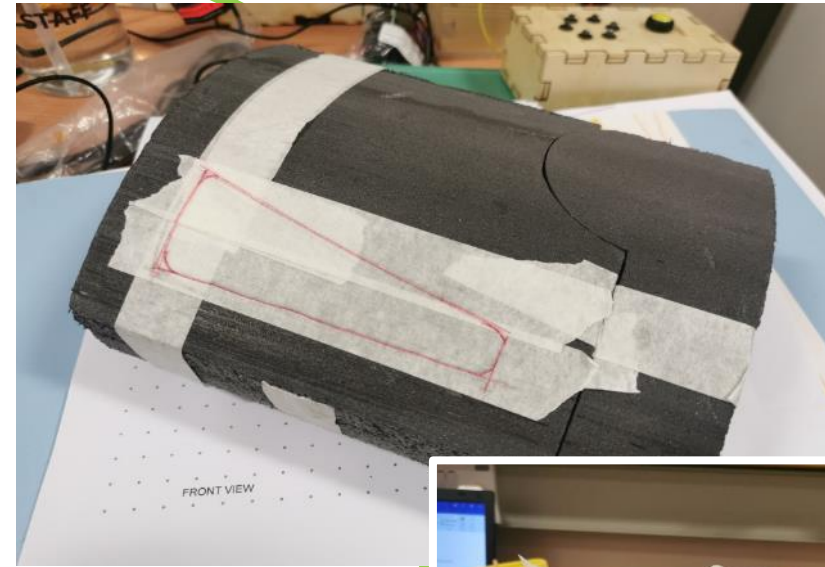
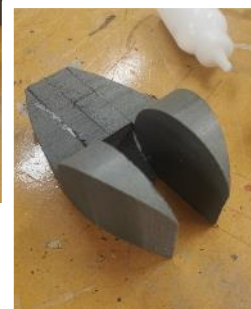
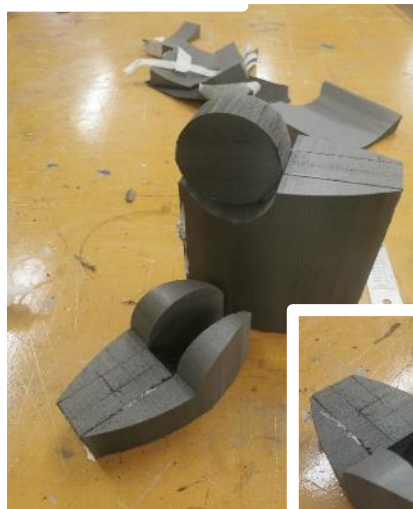
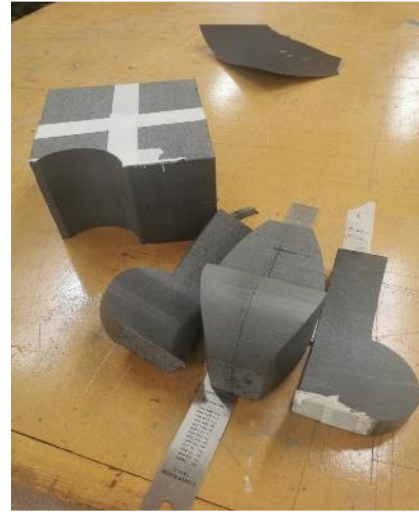

To achieve the handle the block was cut through and then re-joined. This removed the need to cut out a slot which could potentially be untidy and inaccurate.

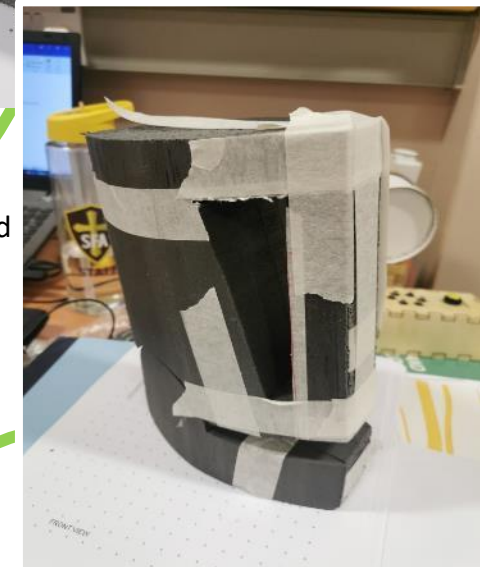

*Material Used : Styrofoam*

## Content Overview

## Assessment Overview

This paper is set out through four sets of questions that predominantly cover technical principles within each endorsed title. Learners will be required to:

- analyse existing products
- demonstrate applied mathematical skills
- demonstrate their technical knowledge of materials, product functionality, manufacturing processes and techniques
- demonstrate their understanding of wider social, moral and environmental issues that impact on the design and manufacturing industries.

### Principles of... (01)

80 marks

1 hour 30 minutes  
written paper

**26.5%**  
of total  
A level

This component has a series of longer answer questions that require learners to demonstrate their problem solving and critical evaluation skills. Learners will be required to:

- apply their knowledge, understanding and skills of designing and manufacturing prototypes and products
- demonstrate their higher thinking skills to solve problems and evaluate situations and suitability of design solutions.

### Problem Solving in...\* (02)

70 marks

1 hour 45 minutes  
written paper

**23.5%**  
of total  
A level

The 'Iterative Design Project' requires learners to undertake a substantial design, make and evaluate project centred on the iterative processes of explore, create and evaluate.

Learners identify a design opportunity or problem from a context of their own choice, and create a portfolio of evidence in real time

### Iterative Design Project\* (03, 04)

100 marks\*\*

Approx. 65 hours

**50%**  
of total  
A level

## Principles of Design

26.7% of the A Level

1 hour and 30 minutes

Summer of Y13

### Principles of 'Design Engineering, Fashion and Textiles or Product Design'

26.7% of A Level

1 hour 30 minutes

Written paper

80 marks

These papers predominantly cover the technical principles of the examined content for each endorsed title.

- There will be sets of questions that are focused around a context or existing product.
- Learners will be required to answer **all** questions.
- The questions will cover a **range** of the outlined exam content.
- There will be a mixture of different levels of questions.
- At least **one** question will require learners to analyse an existing product.
- At least **one** question will require learners to apply mathematical skills that are appropriate to design or technology.
- There may be questions requiring learners to use annotated sketching to communication of the construction of a product.
- There will be **one extended answer question**. The questions will not assess spelling, punctuation and grammar, but will assess the use of subject terminology and the quality of extended response.
- The extended response question will require learners to draw on their synoptic knowledge from across the specification. (The NEA and 'Problem Solving' paper will offer further opportunities to assess this further).
- Use of calculators is permitted in the written examination.

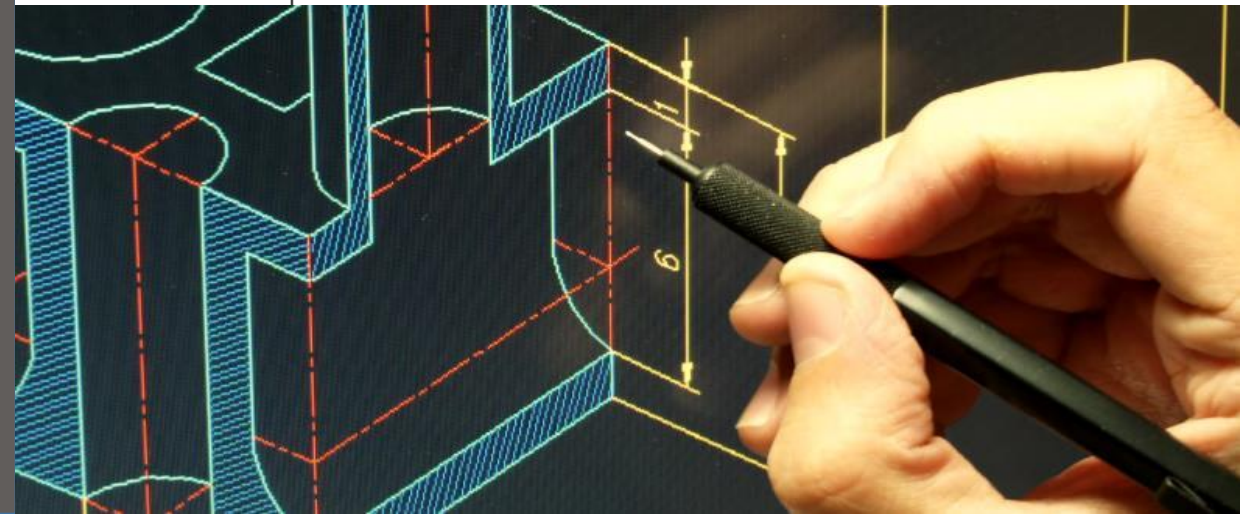



Answer all the questions.

- 1 Fig. 1 shows three images of a selfie stick. A selfie stick is a hand held product used to take photographs or video by holding a smartphone, beyond the normal range of the arm.

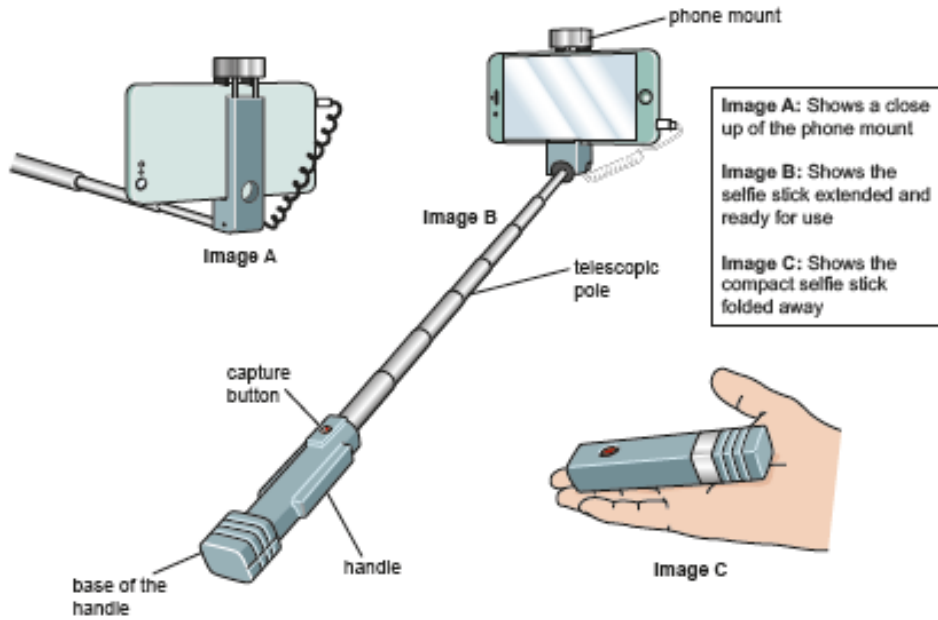

Fig. 1

- (a) Analyse Fig. 1 to identify two design features of the selfie stick that ensure it functions as intended. Justify each of your responses.

1 .....

.....

.....

.....

.....

.....

.....

.....

.....

.....

.....

.....

.....

Fig. 2.2 shows a CAD diagram of the central buttons in the lower part of the remote control. Arc X is part of the outer circumference of a circular array of four identical buttons.

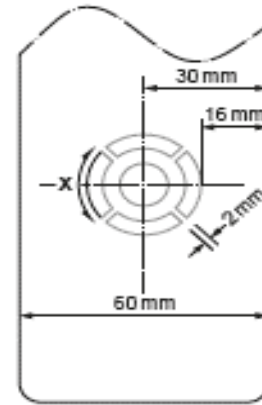

Fig. 2.2 (not to scale)

- (e) Using the diagram in Fig. 2.2, calculate the length of arc X in mm to 2 decimal places. Show your working.

The formula used to calculate the arc length of a circle is

$$\frac{\theta}{360^\circ} \times 2\pi r$$

Length of arc X ..... mm

## Problem Solving

23.3% of the A Level

1 hour and 45 minutes

Summer of Y13

### Problem Solving in 'Design Engineering, Fashion and Textiles or Product Design'

23.3% of A Level

1 hour 45 minutes

Written paper

70 marks

These papers require learners to apply their higher level critical problem solving skills to evaluate the suitability of design solutions to requirements in relation to specific situations.

- Learners will be required to apply their knowledge and understanding of technical and designing principles from the examined content of each endorsed title.
- Learners will be required to answer **all** questions.
- Learners will be given an insert booklet that sets out contextualised detailed information related to the question paper, as well as data covering the data sources from Section 5e that are relevant to each endorsed title.
- Learners will be required to answer a series of longer answer questions that require learners to demonstrate their problem solving and critical evaluation skills.
- At least **one** question will require learners to apply mathematical skills.
- At least half of the marks for this paper will require learners to demonstrate in-depth knowledge and understanding of materials, manufacturing processes and techniques and technical understanding.
- At least **two** questions will require learners to reflect on context of design of:
  - the implications of wider factors of design and technology
  - current trends,
  - understanding of design thinking and communication.
- There will be **two extended answer questions**, these questions will not assess spelling, punctuation and grammar, but will assess the use of subject terminology and the quality of extended responses.
- The extended response questions will require learners to demonstrate synoptic knowledge from across the specification. (The NEA 'Principles' written paper will offer further opportunities to address this further).
- Use of calculators is permitted in the written examination.

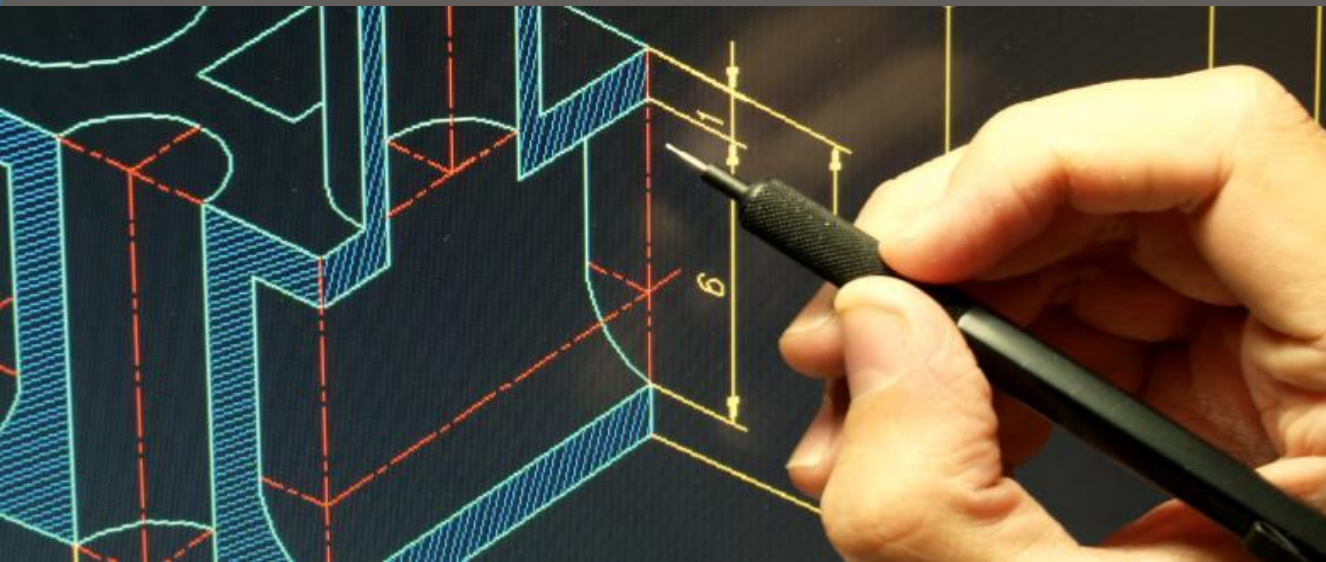

The stimulus in this booklet relates to issues and opportunities encountered with the care and well-being of small domestic pets.

The following article from a news website raises an issue that industry in the UK.

### Pets in the Doghouse as Ownership Falls

When it comes to the cost of owning a pet, many people in enough money in the 'kitty'. Modern economic pressures mean Just 56% now have one, down from 63% five years ago. Gu favour. In 2012, 10% of households kept them but the level i

### Market Research

In response to this worrying trend, the Pet Retailer's Association stakeholders, including pet owners and retailers, to identify contributing to the decline in ownership of small caged pet

The most common response related to a shortfall in the with the purpose of dispensing food automatically to holiday. A limited range of products is currently available

### Design Opportunity

In response to the research, a manufacturer 'Pets4' will address this market research finding and complete hopes by seizing this design opportunity that the follo

1. The care of small pets when owners are on holiday
2. The overall cost of caring for a small pet when costly 'pet sitter'.
3. Sales from the new range of products will counter declining market in small caged pets improve

Pets4You commissions a designer to start work on The designer chooses to base initial ideas on numbers have declined significantly in recent years (see Fig. 1 below) and the types of cages currently Skyline Maxi Small Pet Cage shown in Fig. 2 animals and the current products available to the opportunities.

### Guinea Pig Facts

A healthy weight of a guinea pig is between 700 and 1200g.	Guinea pigs are between 20 and 25 cm long.	The life span of a guinea pig is between 4 and 7 years.
--	--	---

Fig. 1



Answer all the questions.

Before responding to the questions in this paper you must spend time reading and familiarising yourself with the Resource Booklet.

- 1 A range of products is available to care for small caged pets such as guinea pigs. Before determining new design opportunities the designer undertakes initial research into these animals and the current products that are available on the market to house them.

The designer knows pet owners are one of the key stakeholder groups that use the current products on the market.

Critically examine the design requirements that would have been taken into account when designing the Skyline Maxi Small Pet Cage to meet the needs of this key stakeholder group.

Refer to information on pages 2 and 3 of the Resource Booklet. Do not refer to the bought accessories in your response. [8]

6

3 The designer takes forward the gravity feed method (Fig. 3) and develops a concept design shown in Fig. 5 of the Resource Booklet.

Use sketches and/or notes to outline suitable methods of manufacture and assembly for the features of the concept design.

You must focus on all parts of the concept design including the lid, tank (including label) and base.

In your response you must include details of:

- materials;
- manufacturing processes;
- finishes;
- assembly methods.

[16]

## Content Overview

## Assessment Overview

This paper is set out through four sets of questions that predominantly cover technical principles within each endorsed title. Learners will be required to:

- analyse existing products
- demonstrate applied mathematical skills
- demonstrate their technical knowledge of materials, product functionality, manufacturing processes and techniques
- demonstrate their understanding of wider social, moral and environmental issues that impact on the design and manufacturing industries.

### Principles of... (01)

80 marks

1 hour 30 minutes  
written paper

**26.5%**  
of total  
A level

This component has a series of longer answer questions that require learners to demonstrate their problem solving and critical evaluation skills. Learners will be required to:

- apply their knowledge, understanding and skills of designing and manufacturing prototypes and products
- demonstrate their higher thinking skills to solve problems and evaluate situations and suitability of design solutions.

### Problem Solving in...\* (02)

70 marks

1 hour 45 minutes  
written paper

**23.5%**  
of total  
A level

The 'Iterative Design Project' requires learners to undertake a substantial design, make and evaluate project centred on the iterative processes of explore, create and evaluate.

Learners identify a design opportunity or problem from a context of their own choice, and create a portfolio of evidence in real time

### Iterative Design Project\* (03, 04)

100 marks\*\*

Approx. 65 hours

**50%**  
of total  
A level

# Initial ideas – 22/06/2022

Where my ideas stem from – 22/06/2022

To obtain my initial ideas I will need to review my master list of requirements and discussions with my primary user and stakeholder, as well as further discussions to inform the design and thinking of my ideas.

## Providing user medication – Function (A)

1

This concept will work to provide a user the medication they need to take, this concept could be made using BBC microbit using extensions. This concept will use a stepper motor that works with the BBC microbit program, it would allow the user to receive their medication each time the button 'A' is pressed. The BBC microbit is connected to the stepper motor and the stepper motor turns 90 degrees clockwise. This function can be a crucial part due to the stepper motor which would work well with other functions and housing.

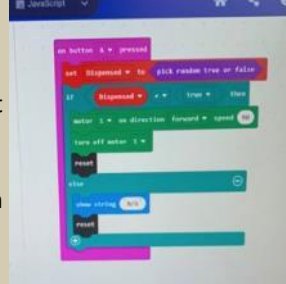

What are the **positives** from this concept? From this concept I can conclude that this concept would be beneficial in my product if I used it for the function. The stepper motor is small and so it would also be compact which contributes to the third requirement in the **master list of requirements**. This concept covers multiple requirements like **providing medication**, having **regular intervals** and being **compact**.

What are the **negatives** from this concept? There is a lot of wiring, and a big battery is used, to overcome this problem I would need to find an **alternative** power source that takes up less space.

Following the development of my initial idea for the function of the product my **next steps** are to **explore** more initial ideas for function and **compare** each function.

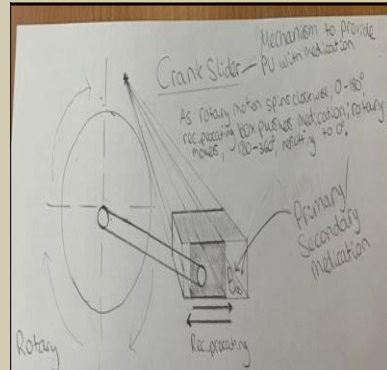
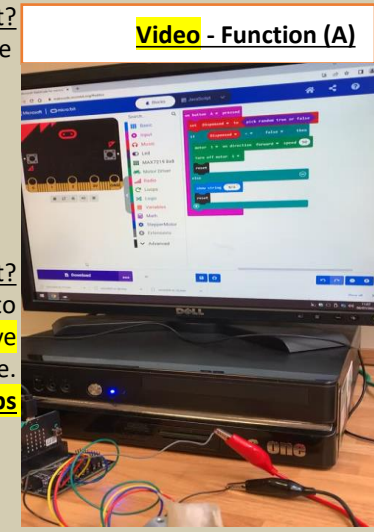

## Providing user medication – Function (B)

2

Function (B) would provide the user with medication through a **crank slider mechanism**. Crank slider involves turning **rotary** motion into **reciprocating** motion, I would use the reciprocating motion to **push** out the user's **primary/secondary medication**. Using a crank slider incorporates a **mechanical** element to the functionality of my project. The crank slider would be the output to a switch being pressed, rotary motion would spin to complete 1 full reciprocating motion to provide pills. Using a **stepper motor** incorporate a **electronic** element to functionality.

To design this concept as a model I have been seeking the advice of my **materials and processes stakeholder**, Mr Wykes, as he has an in depth knowledge of laserscript **CAD** and **traditional methods** of design. His advice has allowed me to build the model in a more efficient way.

## Providing user medication – Function (C)

3

The concept will use a **rack and pinion** mechanism to provide the user with medication. The rack and pinion will be connected to a stepper motor which will allow it to **work in intervals**. Rack and pinion mechanism is **mechanical** and will **work hand in hand** with a stepper motor which is **electrical**. I have invested in a stepper motor, BBC microbit and wires to further develop this initial idea and test what I can achieve with it using the microbit programme. I have had a rack and pinion mechanism **3D printed** and so this physical copy will help me understand how I can develop code from microbit, making the most efficient concept.

Rack and pinion function – CAD photo

The rack and pinion mechanism can work hand in hand with other functions like the crankslder or raspberry pi if those functions become further developed, the rack and pinion will most likely be used with other functions rather than a main function.

## Final initial development - Video

### Lazer cutting plywood - Video



I have used 2D Design **CAD** to create an initial model for the crankslder concept, the model on 2D design was then transferred to the 'laserscript' CAD program which works together with the **laser cutter**. Originally, I used **carboard** material to model the crankslder, however after modelling it I realised that it was too weak for it function as intended and so I decided to use **plywood (iteration)**. Once the 3mm plywood has been cut in respect to the design on the CAD, I modelled the crankslder using **traditional methods** like measuring, **drilling** with a **6mm** drill-bit and using the glue gun. **Iterative design** has been used for this initial model to make it work more efficiently, I have remade arms of the crankslder several times in order for it to work more efficiently, a guard rail for the pills have been added onto the model so that the pills can only travel in one direction, the initial 6mm hole for the screw was drilled higher for the arms to work more efficiently in motion, and a pusher was made so pills can get caught while they are being slid out.



## Raspberry Pi – Function (D)

The raspberry Pi is a small computer which will allow me to develop and support the function of my automated pill dispenser. The Raspberry Pi has multiple USB ports which allows the connection of things that support my product like the BBC micro bit with the motor driver. If the Raspberry Pi concept is taken forward an updated Raspberry Pi can provide Bluetooth connection and a screen monitor that could display things like how long until the next round of medication is available.



My **materials and processes stakeholder** Mr Wyke's has provided me with a raspberry Pi to experiment with, after initially experimenting with the raspberry pi I believe that I could potentially use this function in my product and so I invested in a Raspberry Pi 4 which incorporates a screen and Bluetooth which can help meet requirements in the **MLR** (Master List of Requirements) like reminding the user and being easy to navigate.

After speaking to one of my **materials and processes stakeholder**, Mr Dawson, I discovered that he teaches lower school how to use a raspberry pi and so he knows how to program one on a basic level, so initially this could be beneficial if I decide to use a raspberry pi in my product. Mr Dawson has also helped other A-Level students in their projects using a raspberry pi. Therefore, a raspberry pi could be useful when looking to meet objectives in the **master list of requirements (MLR)** like giving reminders to the user and setting regular intervals.

Stakeholder text message comments



Video

## Sliding lid – Function/Housing (E)

This concept was inspired by a lids typically found on spices. The sliding lid concept would work in a way so that it would open at a certain period of the day and then close after the pills are taken, and the next time the pill box would open is the next day at the same designated time. The concept would operate simultaneously with a stepper motor, programmed on BBC microbit.

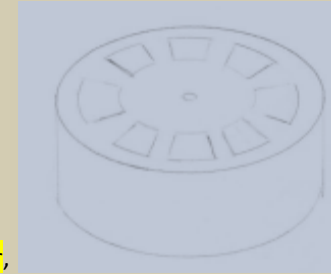

Video

Mr Wykes, the **materials and processes stakeholder**, has helped me by providing me with advice on how to use the process of laser cutting as well as using traditional methods of design when making the cardboard model.

### Laser cutting process

This design idea was created in 2D design so that it could be sent and transferred to the laser cutter using a USB. Once transferred to the laser it cuts it out precisely.

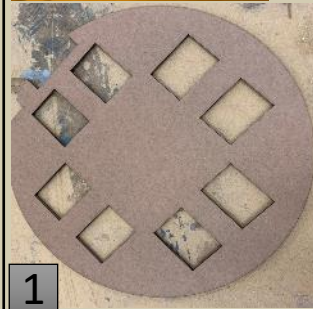
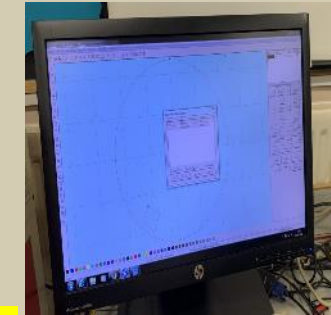

1

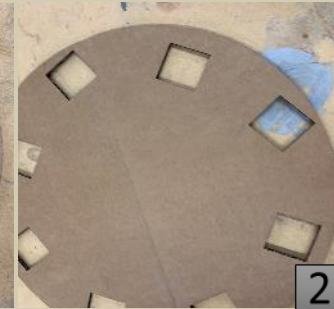

2

### Iterative process

Concepts have been developed to work more efficiently, as seen in the first draft of this function the top face lid would not be able to be as effective as the second draft. The second draft of the lid is easier for design and use for the user.

In the second draft the holes are angled and spread out appropriately to fit with the top face lid.



### Final comments for (E)

- The sliding lid concept has a pencil going through the middle to simulate a stepper motor
- A stepper motor will replace the pencil when the concept is further developed and/or the stepper motor function works effectively with the BBC micro bit program.
- If the concept is taken further than the next steps of this would be to design the housing like it is in the sketch.

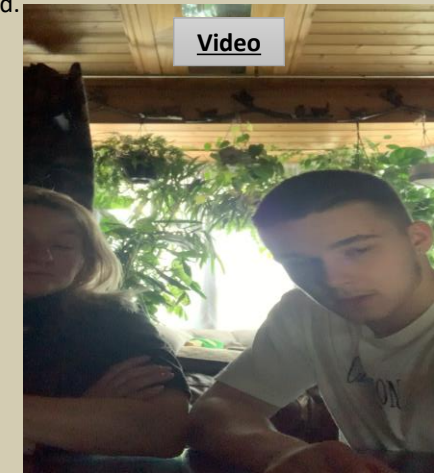

Video