

Sixth Form Evening November 2024

Physics at St. Francis



Welcome

- ▶ Introduction to the department
- ▶ A-level break down and assessment
- ▶ PAGs and application
- ▶ St. Francis results and outcomes
- ▶ Entry requirements
- ▶ Career Pathways
- ▶ Questions



Science Department

Dedicated A-level Physics teachers:

Dr K. Berry H. Makibi



Current A-Level Physics A course

- ▶ Currently we have 11 year 13 students and 13 year 12 students studying the OCR - Physics A course
- ▶ Each student has 6 dedicated lessons per week on a fixed timetable as well as independent study.



A-level break down

- ▶ OCR - Physics A
- ▶ 6 individual modules.
- ▶ 3 formal exams taken at the end of the course in May/June.
- ▶ Modules 3, 4, 5 and 6 are the core modules.
- ▶ Modules 1 and 2 are assessed throughout within PAGs and also application of knowledge

Content Overview	Assessment Overview	
<p>Content is split into six teaching modules:</p> <ul style="list-style-type: none"> • Module 1 – Development of practical skills in physics • Module 2 – Foundations of physics • Module 3 – Forces and motion • Module 4 – Electrons, waves and photons • Module 5 – Newtonian world and astrophysics • Module 6 – Particles and medical physics <p>Component 01 assesses content from modules 1, 2, 3 and 5.</p> <p>Component 02 assesses content from modules 1, 2, 4 and 6.</p> <p>Component 03 assesses content from all modules (1 to 6).</p>	<p>Modelling physics (01)</p> <p>100 marks</p> <p>2 hours 15 minutes</p> <p>written paper</p>	<p>37%</p> <p>of total A level</p>
	<p>Exploring physics (02)</p> <p>100 marks</p> <p>2 hours 15 minutes</p> <p>written paper</p>	<p>37%</p> <p>of total A level</p>
	<p>Unified physics (03)</p> <p>70 marks</p> <p>1 hour 30 minutes</p> <p>written paper</p>	<p>26%</p> <p>of total A level</p>
	<p>Practical Endorsement in physics (04)</p> <p>(non exam assessment)</p>	<p>Reported separately (see Section 5g)</p>

- ▶ **Module 1 - Development of practical skills in physics**
- ▶ 1.1 Practical skills assessed in a written examination
- ▶ 1.2 Practical skills assessed in the practical endorsement
- ▶ **Module 2 - Foundations of physics**
- ▶ 2.1 Physical quantities and units
- ▶ 2.2 Making measurements and analysing data
- ▶ 2.3 Nature of quantities
- ▶ **Module 3 - Forces and motion**
- ▶ 3.1 Motion
- ▶ 3.2 Forces in action
- ▶ 3.3 Work, energy and power
- ▶ 3.4 Materials
- ▶ 3.5 Newton's laws of motion and momentum
- ▶ **Module 4 - Electrons, waves and photons**
- ▶ 4.1 Charge and current
- ▶ 4.2 Energy, power and resistance
- ▶ 4.3 Electrical circuits
- ▶ 4.4 Waves
- ▶ 4.5 Quantum physics
- ▶ **Module 5 - Newtonian world and astrophysics**
- ▶ 5.1 Thermal physics
- ▶ 5.2 Circular motion
- ▶ 5.3 Oscillations
- ▶ 5.4 Gravitational fields
- ▶ 5.5 Astrophysics and cosmology
- ▶ **Module 6 - Particles and medical physics**
- ▶ 6.1 Capacitors
- ▶ 6.2 Electric fields
- ▶ 6.3 Electromagnetism
- ▶ 6.4 Nuclear and particle physics
- ▶ 6.5 Medical imaging



PAGs

Practical Activity Groups

- ▶ Each PAG has 2 or 3 options for successful completion.
- ▶ Successful completion includes:
 - ❖ Completing practical
 - ❖ Recording results
 - ❖ Graphical analysis
 - ❖ Conclusive overview

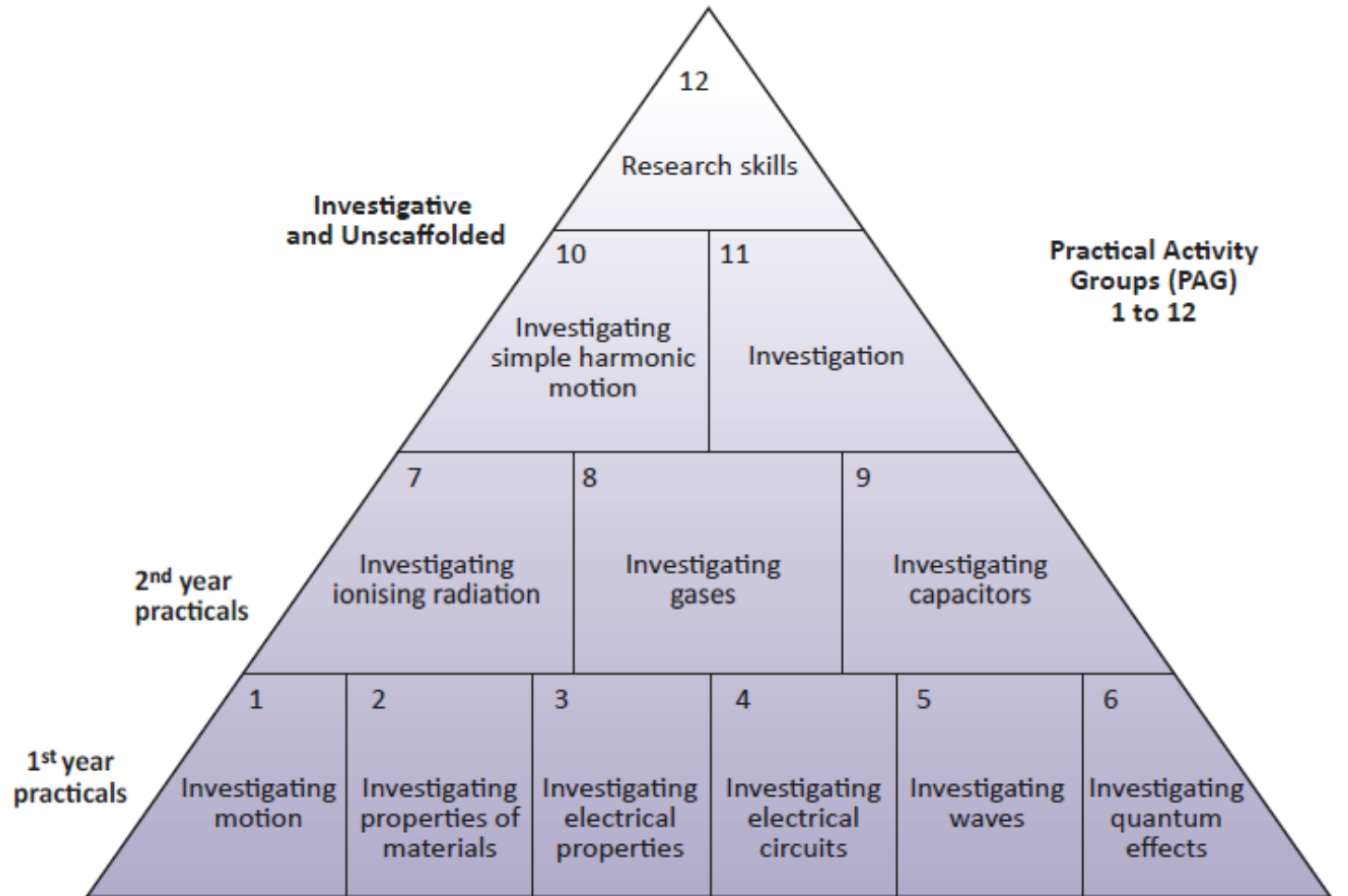

Pag 2.2 - Young's Modulus

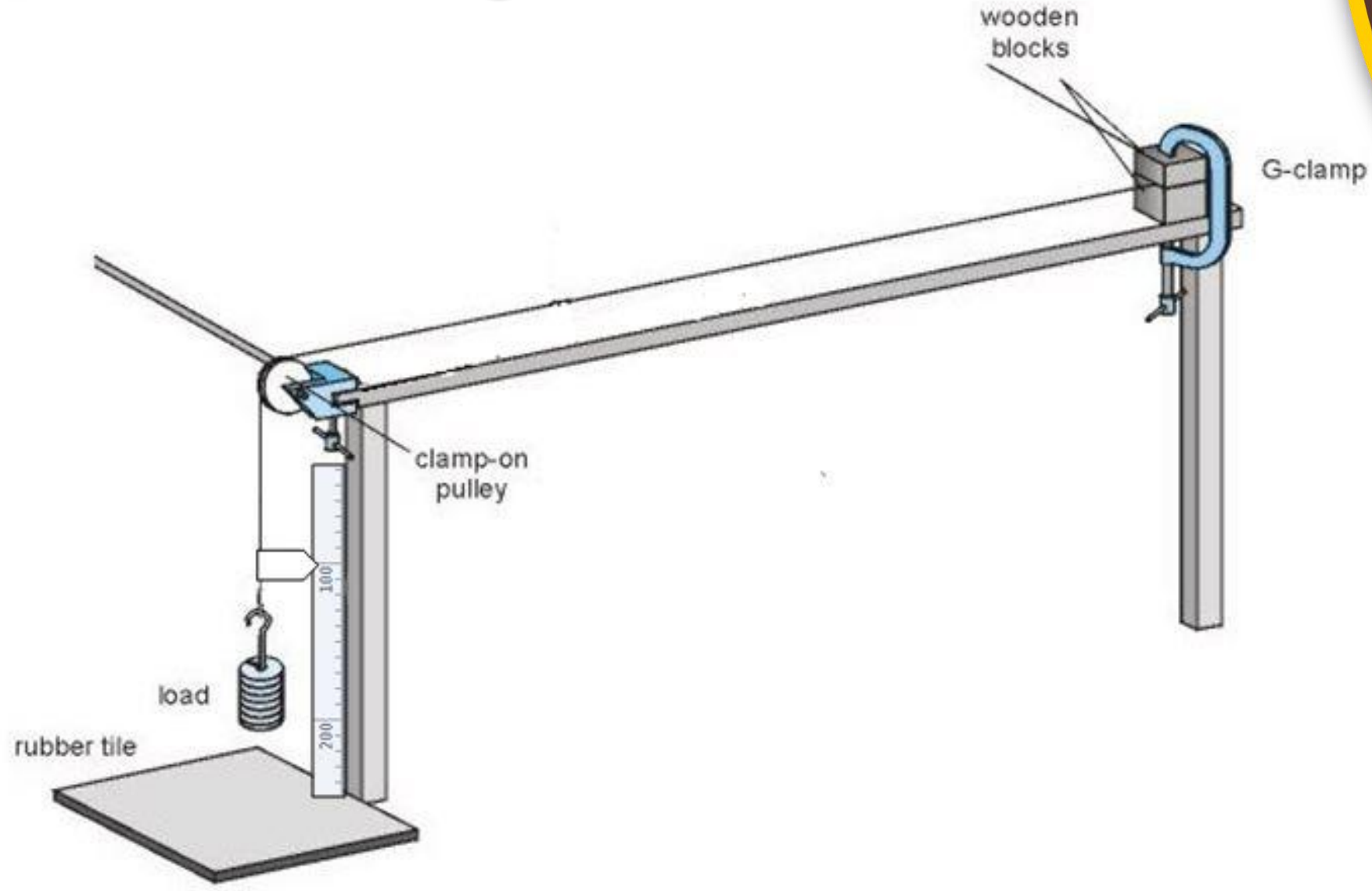

Pag 3.1 - Resistivity of a wire

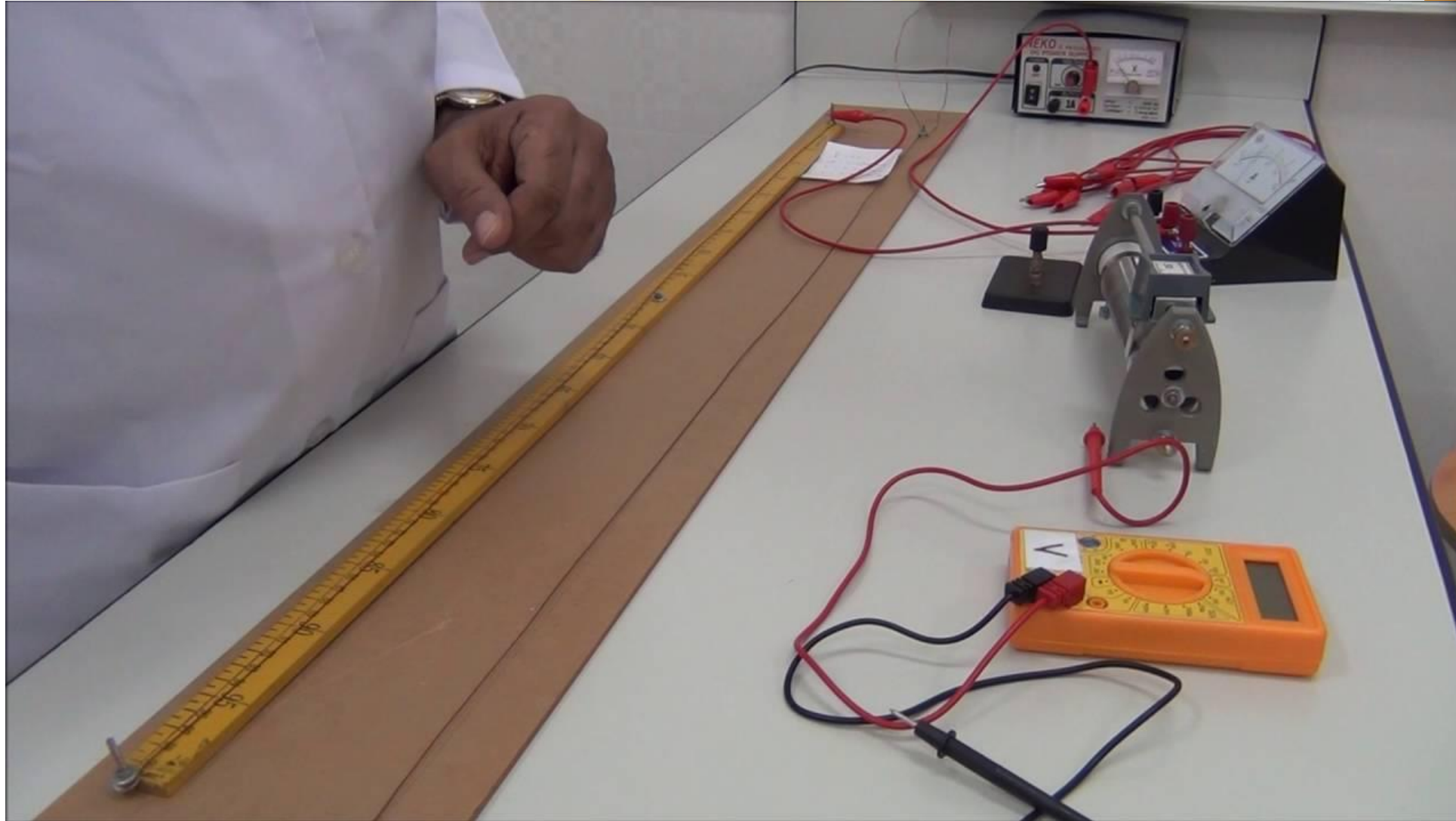

Pag 5.1 - Determining wavelength of a laser using a diffraction grating

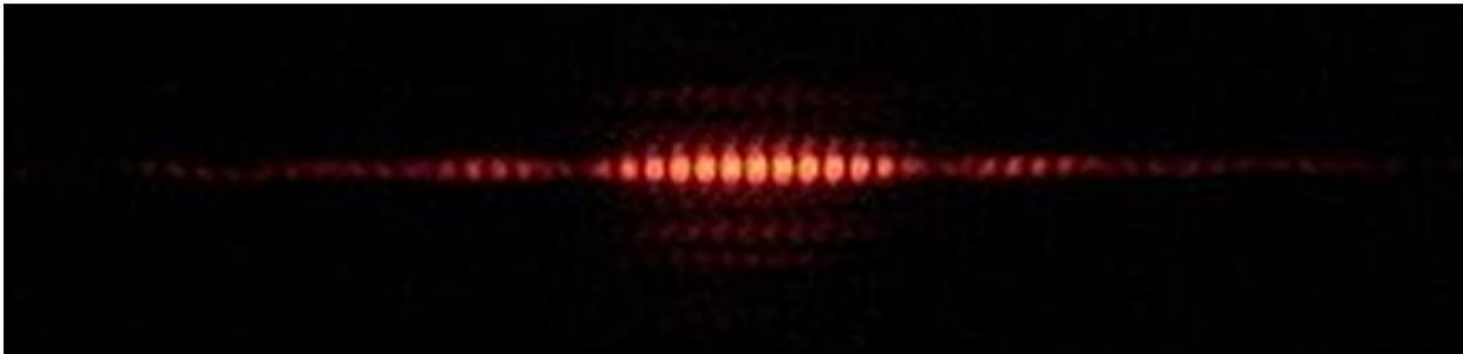
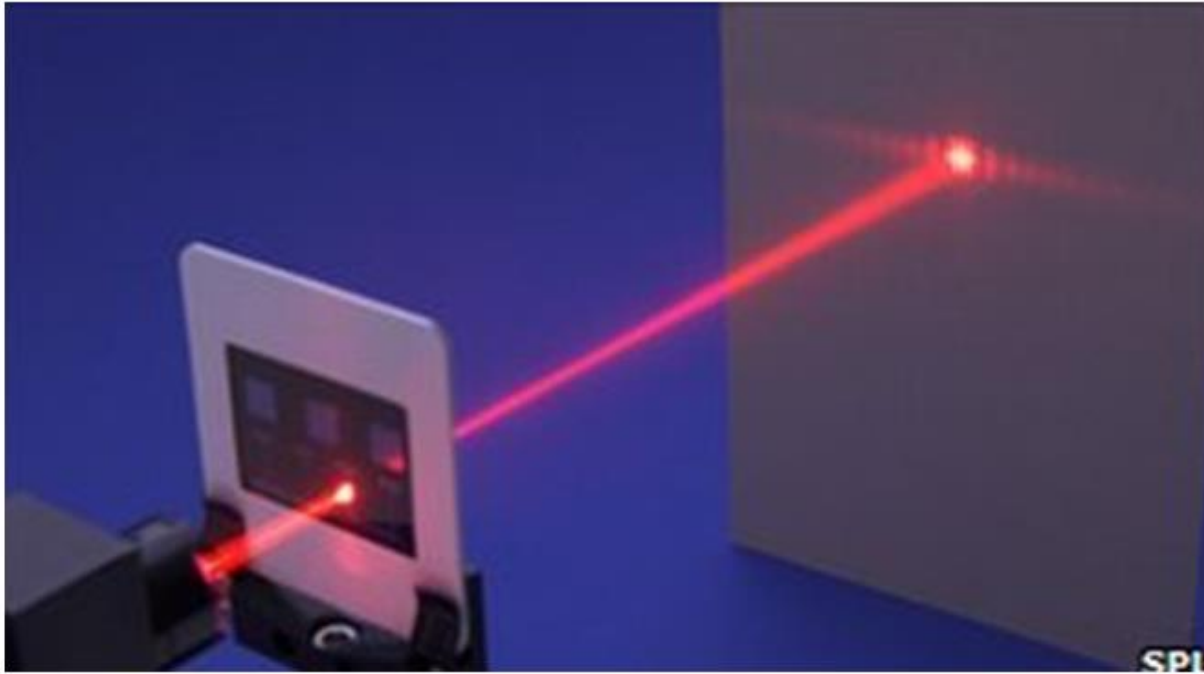

Pag 6.1 Investigating the randomness of radiation



Physics Specific Career Pathways

- ▶ Geophysicist/field seismologist
- ▶ Healthcare scientist, medical physics
- ▶ Radiation protection practitioner
- ▶ Research scientist (physical sciences)
- ▶ Scientific laboratory technician
- ▶ Secondary school teacher
- ▶ Meteorologist
- ▶ Operational researcher
- ▶ Systems developer
- ▶ Airline Pilot
- ▶ Aerospace engineer
- ▶ Software development
- ▶ Practical assessor
- ▶ Mathematics



2021 Y13 Results	A*	A	B	C	D	E	U	Total
Physics	1	1	0	2	0	0	0	4
2022 Y13 Results	A*	A	B	C	D	E	U	Total
Physics	0	2	0	1	1	1	0	5
2023 Y13 Results	A*	A	B	C	D	E	U	Total
Physics	1	2	3	4	0	2	1	13
2024 Y13 Results	A*	A	B	C	D	E	U	Total
Physics	1	0	3	3	3	1	1	12



Entry Requirements

7, 6 in Combined Science
Or
7 in Physics.

Must also have at least a grade 7 in Mathematics.

****Note****

To study two A level Sciences, you will need a grade 7,7 on combined sciences.

To study three A level Sciences, you will need a grade of 8,7 on combined sciences.



Questions?

- ▶ Thank you for your attendance

Contact email:

hmakibi@stfrancis.cc

kberry@stfrancis.cc

